

M2i.ClkDist / M2i.ClkDist-exp - Clock and Trigger Distribution Card

- Easy synchronization of distributed systems
- 2 independent 1 onto 17 distribution channels for 2 x clock or clock and trigger
- Very low channel-to-channel skew
- Passive PCI or PCI Express card, no programming necessary
- LVTTTL outputs, capable of driving 50 ohm loads
- Outputs can be deactivated by jumper
- As an option: useable as clock source equipped with separately ordered quartz oscillator

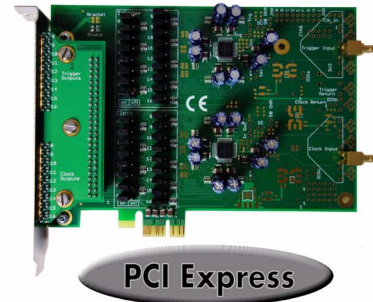

Hardware block diagram

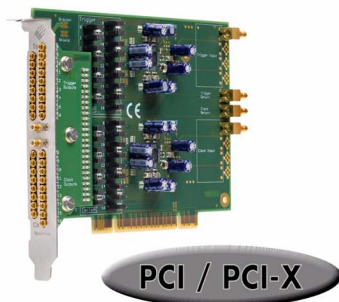
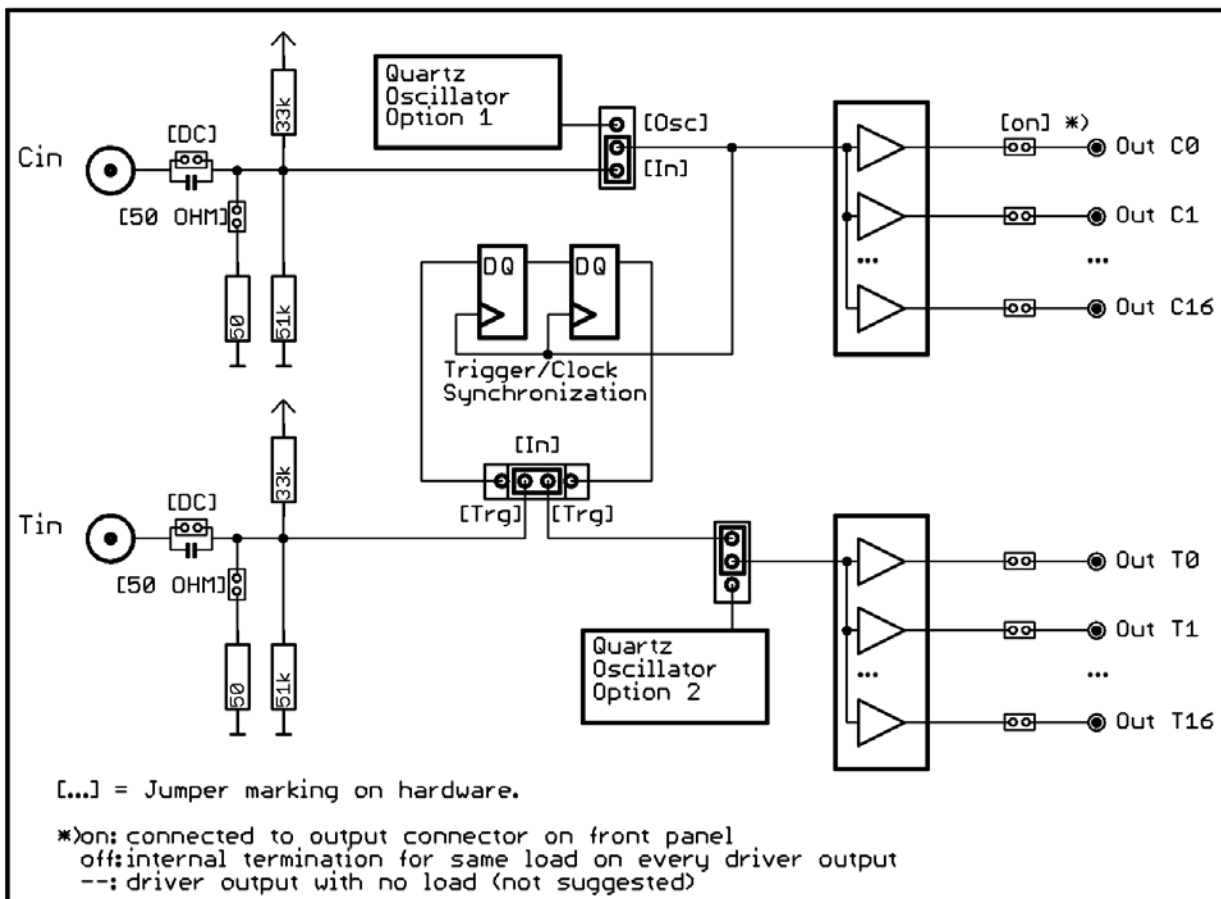

Technical Data

Inputs

Input voltage low level	$\geq 0 \text{ V}$ and $\leq 0.8 \text{ V}$ (min level -0.3 V)
Input voltage high level	$\geq 2.0 \text{ V}$ and $\leq 3.3 \text{ V}$ (max level 3.8 V)
Trigger pulse width on sync feature use	≥ 2 samplings clocks
Termination	20 kOhm, selectable per jumper to 50 ohm
Coupling	DC, selectable by jumper to AC
Max input clock rate	167 MHz
Max trigger synchronization rate	125 MHz
Connector type	3mm SMB male

Outputs

Output voltage low level (50 ohm load)	$\geq 0 \text{ V}$ and $\leq 0.5 \text{ V}$
Output voltage high level (50 ohm load)	$\geq 2.4 \text{ V}$ and $\leq 3.3 \text{ V}$
max channel to channel skew (one bank)	150 ps
max channel to channel skew (all outputs)	275 ps
Output impedance (typical)	7 ohm
Max propagation delay	4.3 ns
Outputs in bank 0	0, 1, 2, 3, 8, 9, 10, 11
Outputs in bank 1	4, 5, 6, 7, 13, 14, 15, 16
Outputs in bank 2	12
Connector type	MMCX female

Power consumption

	PCI/PCI-X 3,3 V	PCIe 3,3V	max Total
Idle Running, no loads	0.7 A	0.7 A	2.3 W
4 output channels 50 ohm load*	0.9 A	0.9 A	3.0 W
17 output channels 50 ohm load*	1.2 A	1.2 A	4.0 W
34 output channels 50 ohm load*	1.6 A	1.6 A	5.3 W

Environmental and Physical details

Dimension (PCB only)	174 mm x 107 mm (half PCI length)
Width	1 slot
Weight	< 200g
Warm up time	10 minutes
Operating temperature	0°C - 50°C

*measured with 125 MHz clock signal, 50% duty cycle

Jumper Placement

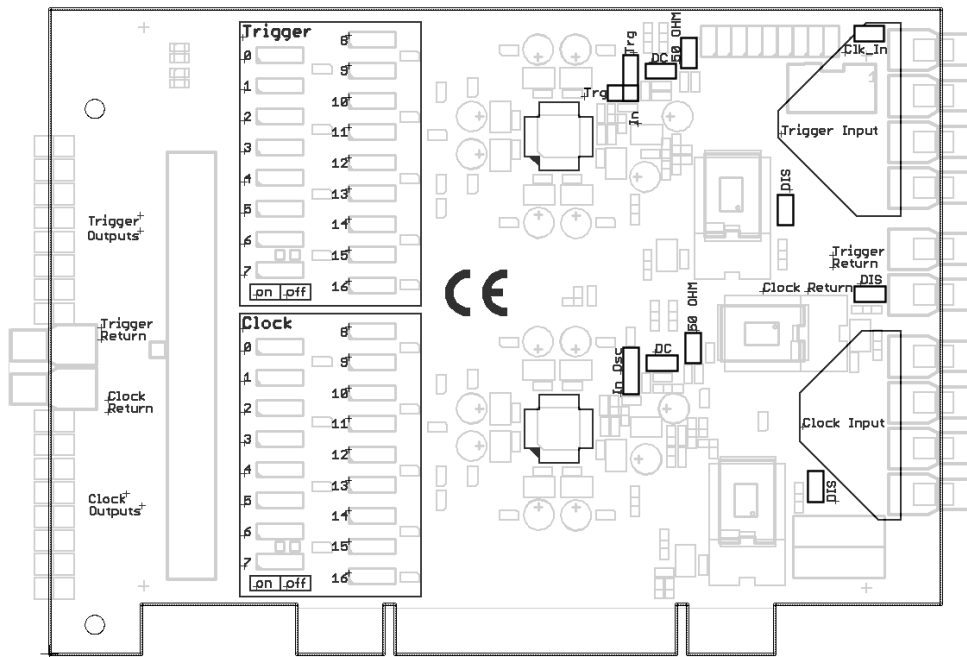

Order Information

PCI/PCI-X

Order no.	Description
M2i.ClkDist	Clock and trigger distribution card with 2 times 1 into 17 channels distribution, short PCI 32 bit card, no cables included
M2i.ClkDist-exp	Clock and trigger distribution card with 2 times 1 into 17 channels distribution, short PCI Express x1 card, no cables included
M2i.ClkDist-xxMyy	Quartz option with xx MHz and a accuracy of yy ppm (e.g. 40M20 = 40 MHz 20 ppm), please request an individual quote.

Cables

Order no.	Option
Cab-1m-9m-80	Adapter cable MMCX male to BNC male, 80 cm
Cab-1m-9f-80	Adapter cable MMCX male to BNC female, 80 cm
Cab-1m-9m-200	Adapter cable MMCX male to BNC male, 200 cm
Cab-1m-9f-200	Adapter cable MMCX male to BNC female, 200 cm
Cab-1m-3f-80	Adapter cable MMCX male to SMB female, 80 cm
Cab-1m-3f-200	Adapter cable MMCX male to SMB female, 200 cm
Cab-3f-9m-80	Adapter cable SMB female to BNC male, 80 cm
Cab-3f-9f-80	Adapter cable SMB female to BNC female, 80 cm
Cab-3f-3f-80	Adapter cable SMB female to SMB female, 80 cm
Cab-3f-9m-200	Adapter cable SMB female to BNC male, 200 cm

Cables

Order no.	Option
Cab-3f-9f-200	Adapter cable SMB female to BNC female, 200 cm
Information	The standard adapter cables are based on RG-174 cables and have a nominal attenuation of 0.3 dB/m at 100 MHz.

Technical changes and printing errors possible

SBench, digitizerNETBOX and generatorNETBOX are registered trademarks of Spectrum Instrumentation GmbH. Microsoft, Visual C++, Windows, Windows 98, Windows NT, Window 2000, Windows XP, Windows Vista, Windows 7, Windows 8 and Windows 10 are trademarks/registered trademarks of Microsoft Corporation. LabVIEW, DASyLab, Diadem and LabWindows/CVI are trademarks/registered trademarks of National Instruments Corporation. MATLAB is a trademark/registered trademark of The Mathworks, Inc. Delphi and C++Builder are trademarks/registered trademarks of Embarcadero Technologies, Inc. Keysight VEE, VEE Pro and VEE OneLab are trademarks/registered trademarks of Keysight Technologies, Inc. FlexPro is a registered trademark of Weisang GmbH & Co. KG. PCIe, PCI Express and PCI-X and PCI-SIG are trademarks of PCI-SIG. LXI is a registered trademark of the LXI Consortium. PICMG and CompactPCI are trademarks of the PCI Industrial Computer Manufacturers Group. Oracle and Java are registered trademarks of Oracle and/or its affiliates. Intel and Intel Core i3, Core i5, Core i7, Core i9 and Xeon are trademarks and/or registered trademarks of Intel Corporation. AMD, Opteron, Sempron, Phenom, FX, Ryzen and EPYC are trademarks and/or registered trademarks of Advanced Micro Devices. NVIDIA, CUDA, GeForce, Quadro and Tesla are trademarks/registered trademarks of NVIDIA Corporation.