

DN2.66x - 8 channel 16 bit generatorNETBOX up to 1.25 GS/s

- 2, 4 or 8 channels with 625 MS/s up to 1.25 GS/s
- Simultaneous arbitrary generation on all channels
- Output signal bandwidth up to 400 MHz
- Output level ± 80 mV to ± 2.5 V (± 2.0 V) into 50Ω (± 160 mV to ± 5 V (± 4 V) into high-impedance loads)
- Fixed trigger to output delay
- Huge 2 GSample (2 x 2 GSample) internal memory
- FIFO mode continuous streaming output
- Modes: Single-Shot, Loop, FIFO, Sequence Replay Mode, Gated, ...

Multi-Tone DDS Option

The DDS firmware option adds a new output mode with 23 individually programmable DDS cores. Each DDS core can be routed to different outputs allowing up to 20 DDS cores for a single output forming a multi-carrier, or multi-tone, signal source.

Each core can be programmed for frequency, amplitude and phase. DDS commands can be issued with 6.4 ns spacing. Advanced commands like frequency slope, amplitude slope or digital outputs can be programmed. A programmable timer as well as external trigger can be used to advance DDS-commands.



- Ethernet Remote Instrument
- LXI Core 2011 compatible
- GBit Ethernet Interface
- Sustained streaming mode up to 100 MB/s
- Direct Connection to PC/Laptop
- Connect anywhere in company LAN
- Embedded Webserver for Maintenance/Updates
- Embedded Server option for open Linux platform

Operating Systems	SBench 6 Professional Included	Drivers
<ul style="list-style-type: none"> • Windows 7 (SP1), 8, 10, Server 2008 R2 and newer • Linux Kernel 2.6, 3.x, 4.x, 5.x • Windows/Linux 32 and 64 bit 	<ul style="list-style-type: none"> • Acquisition, Generation and Display of analog and digital data • Calculation, FFT • Documentation and Import, Export 	<ul style="list-style-type: none"> • LabVIEW, MATLAB, LabWindows/CVI • C/C++, GNU C++, VB.NET, C#, J#, Delphi, Java, Python • IVI

Model	Bandwidth	Resolution	Channels	Sampling Rate	AWG Modules	Internal Star-Hub
DN2.663-04	400 MHz	16 Bit	4	1.25 GS/s	2	yes
DN2.663-02	400 MHz	16 Bit	2	1.25 GS/s	1	no
DN2.662-08	200 MHz	16 Bit	8	625 MS/s	2	yes
DN2.662-04	200 MHz	16 Bit	4	625 MS/s	1	no
DN2.662-02	200 MHz	16 Bit	2	625 MS/s	1	no

General Information

The generatorNETBOX DN2.66x series allows generation of arbitrary signals on up to 8 channels with update (sampling) rates of 625 MS/s or 4 channels with up to 1.25 GS/s. These Ethernet Remote instruments offer outstanding D/A features both in resolution and signal quality.

The combination of high sampling rate and resolution makes these AWGs the top-of-the-range for applications that require high quality signal generation.

The generatorNETBOX can be installed anywhere in the company LAN and can be remotely controlled from a host PC.

Software Support

Windows Support

The digitizerNETBOX/generatorNETBOX/hybridNETBOX can be accessed from Windows 7, Windows 8, Windows 10 (either 32 bit or 64 bit). Programming examples for Visual C++, C++ Builder, LabWindows/CVI, Delphi, Visual Basic, VB.NET, C#, Julia, Python, Java and IVI are included.

Linux Support



The digitizerNETBOX/generatorNETBOX/hybridNETBOX can be accessed from any Linux system. The Linux support includes SMP systems, 32 bit and 64 bit systems, versatile programming examples for Gnu C++, Python, Julia as well as drivers for MATLAB for Linux. SBench 6, the powerful data acquisition and analysis software from Spectrum is also included as a Linux version.

Discovery Protocol

Physical Location	
Bus No	0
Device No	0
Function No	0
Slot No	0
IP	192.168.169.14
VISA	TCPIP[0]:192.168.169.14:inst0:INSTR

The Discovery function helps you to find and identify any Spectrum LXI instruments, like the digitizerNETBOX and generatorNETBOX, available to your computer on the network.

The Discovery function will also locate any Spectrum card products that are managed by an installed Spectrum Remote Server somewhere on the network.

After running the discovery function the card information is cached and can be directly accessed by SBench 6. Furthermore the qualified VISA address is returned and can be used by any software to access the remote instrument.

SBench 6 Professional

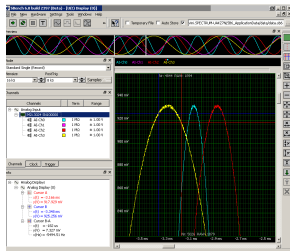

The digitizerNETBOX, generatorNETBOX and hybridNETBOX can be used with Spectrum's powerful software SBench 6 – a Professional license for the software is already installed in the box. SBench 6 supports all of the standard features of the instrument. It has a variety of display windows as well as analysis, export and documentation functions.

- Available for Windows 7, Windows 8, Windows 10 and Linux
- Easy to use interface with drag and drop, docking windows and context menus
- Display of analog and digital data, X-Y display, frequency domain and spread signals
- Designed to handle several GBytes of data
- Fast data preview functions

IVI Driver

The IVI standards define an open driver architecture, a set of instrument classes, and shared software components. Together these provide critical elements needed for instrument interchangeability. IVI's defined Application Programming Interfaces (APIs) standardize common measurement functions reducing the time needed to learn a new IVI instrument.

The Spectrum products to be accessed with the IVI driver can be locally installed data acquisition cards, remotely installed data acquisition cards or remote LXI instruments like

digitizerNETBOX/generatorNETBOX. To maximize the compatibility with existing IVI based software installations, the Spectrum IVI driver supports IVI Scope, IVI Digitizer and IVI FGen class with IVI-C and IVI-COM interfaces.

Third-party Software Products

Most popular third-party software products, such as LabVIEW, MATLAB or LabWindows/CVI are supported. All drivers come with examples and detailed documentation.

Embedded Webserver

SPECTRUM INSTRUMENTATION	
Welcome	
Instrument Model	DN2.465-08
Manufacturer	Spectrum GmbH
Serial Number	1234
Description	digitizerNETBOX
LXI Features	LXI Core 2011
LXI Version	LXI Device Specification 2011 rev. 1.4
Host Name	192.168.169.23
mDNS Host Name	digitizerNETBOX.local
MAC Address	0C:C4:7A:B3:C2:A2
TCP/IP Address	192.168.169.23
Firmware Revision	62
Software Revision	5.17.17117
Instrument Address String [VISA]	TCPIP::192.168.169.23::INSTR
LAN ID Indicator	<input type="checkbox"/> Enable

The integrated webserver follows the LXI standard and gathers information on the product, set up of the Ethernet configuration and current status. It also allows the setting of a configuration password, access to documentation and updating of the complete instrument firmware, including the embedded remote server and the webserver.

Hardware features and options

LXI Instrument



The digitizerNETBOX and generatorNETBOX are fully LXI instrument compatible to LXI Core 2011 following the LXI Device Specification 2011 rev. 1.4. The digitizerNETBOX/generatorNETBOX has been tested and approved by the LXI Consortium.

Located on the front panel is the main on/off switch, LEDs showing the LXI and Acquisition status and the LAN reset switch.

Chassis features



The chassis is especially designed for usage in different application areas and has some advanced features for mobile and shared usage:

- stable metal chassis
- 8 bumper edges protect the chassis, the desk and other components on it. The bumper edges allow to store the chassis either vertically or horizontally and the lock-in structure allows to stack multiple chassis with a secure fit onto each other. For 19" rack mount montage the bumpers can be unmounted and replaced by the 19" rack mount option
- The handle allows to easily carry the chassis around in just one hand.
- A standard GND screw on the back of the chassis allows to connect the metal chassis to measurement ground to reduce noise based on ground loops and ground level differences.

Front Panel



Standard SMA connectors are used for all analog input signals and all trigger and clock signals. No special adapter cables are needed and the connection is secure even when used in a moving environment.

Custom front panels are available on request even for small series, be it BNC, LEMO connectors or custom specific connectors.

Three additional XIO lines

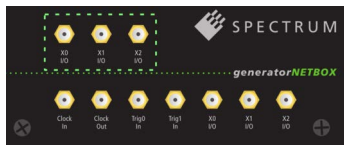

The generatorNETBOX that contain two AWG generator cards can optionally extended, such that the three additional XIO lines (marker output) of second internal

AWG are also routed to the to front-plate. This option is only available for the DN2.662-08 and DN2.663-04 models.

Ethernet Connectivity



The GBit Ethernet connection can be used with standard COTS Ethernet cabling. The integration into a standard LAN allows to connect the digitizerNETBOX/generatorNETBOX either directly to a desktop PC or Laptop or it is possible to place the instrument somewhere in the

company LAN and access it from any desktop over the LAN.

DC Power Supply Option



The digitizerNETBOX/generatorNETBOX/hybridNETBOX can be equipped with an internal DC power supply which replaces the standard AC power supply. This power supply options is available with an input range of nominal 24 V. Contact the sales team if other DC levels are required.

Using the DC power supply the device can be used for mobile applications together with a Laptop in automotive or airborne applications.

Boot on Power Option

The digitizerNETBOX/generatorNETBOX can be factory configured to automatically start and boot upon availability of the input power rail. That way the instrument will automatically become available again upon loss of input power.

Option Embedded Server

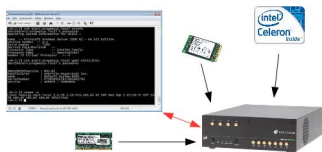

The option turns the digitizerNETBOX/generatorNETBOX in a powerful PC that allows to run own programs on a small and remote data acquisition system. The digitizerNETBOX/generatorNETBOX is enhanced by more memory, a powerful CPU, a freely accessible internal SSD and a remote software development access method.

The digitizerNETBOX/generatorNETBOX can either run connected to LAN or it can run totally independent, storing data to the internal SSD. The original digitizerNETBOX/generatorNETBOX remote instrument functionality is still 100 % available. Running the embedded server option it is possible to pre-calculate results based on the acquired data, store acquisitions locally and to transfer just the required data or results parts in a client-server based software structure. A different example for the digitizerNETBOX/generatorNETBOX embedded server is surveillance/logger application which can run totally independent for days and send notification emails only over LAN or offloads stored data as soon as it's connected again.

Access to the embedded server is done through a standard text based Linux shell based on the ssh secure shell.

Singleshot output

When singleshot output is activated the data of the on-board memory is played exactly one time. The trigger source can be either one of the external trigger inputs or the software trigger. After the first trigger additional trigger events will be ignored.

Repeated output

When the repeated output mode is used the data of the on-board memory is played continuously for a programmed number of times or until a stop command is executed. The trigger source can be either one of the external trigger inputs or the software trigger. After the first trigger additional trigger events will be ignored.

Single Restart replay

When this mode is activated the data of the on-board memory will be replayed once after each trigger event. The trigger source can be either the external TTL trigger or software trigger.

FIFO mode

The FIFO mode is designed for continuous data transfer between PC memory or hard disk and the generation board. The control of the data stream is done automatically by the driver on an interrupt request basis. The complete installed on-board memory is used for buffering data, making the continuous streaming extremely reliable.

Multiple Replay

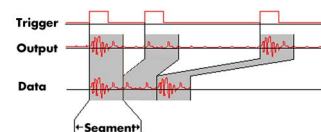

The Multiple Replay mode allows the fast output generation on several trigger events without restarting the hardware. With this option very fast repetition rates can be

achieved. The on-board memory is divided into several segments of the same size. Each segment can contain different data which will then be played with the occurrence of each trigger event.

Gated Replay

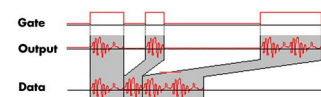

The Gated Sampling mode allows data replay controlled by an external gate signal. Data is only replayed if the gate signal has attained a

programmed level.

Sequence Mode

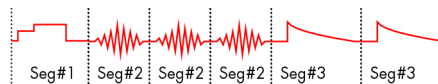

The sequence mode allows to split the card memory into sev-

eral data segments of different length. These data segments are chained up in a user chosen order using an additional sequence memory. In this sequence memory the number of loops for each segment can be programmed and trigger conditions can be defined to proceed from segment to segment. Using the sequence mode it is also possible to switch between replay waveforms by a simple software command or to redefine waveform data for segments simultaneously while other segments are being replayed. All trigger-related and software-command-related functions are only working on single cards, not on star-hub-synchronized cards.

External trigger input

All boards can be triggered using up to two external analog or digital signals. One external trigger input has two analog comparators that can define an edge or window trigger, a hysteresis trigger or a rearm trigger. The other input has one comparator that can be used for standard edge and level triggers.

External clock input and output

Using a dedicated connector a sampling clock can be fed in from an external system. Additionally it's also possible to output the internally used sampling clock on a separate connector to synchronize external equipment to this clock.

Reference clock

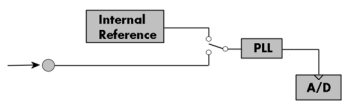

The option to use a precise external reference clock (normally 10 MHz) is necessary to synchronize the instrument for high-quality measurements with external equipment (like a signal source). It's also possible to enhance the quality of the sampling clock in this way. The driver automatically generates the requested sampling clock from the fed in reference clock.

Firmware Option Digital Pulse Generator

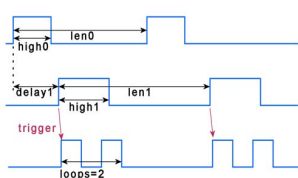

The digital pulse generator option adds 4 internal independent digital pulse generators with programmable duty cycle, output frequency, delay and number of loops.

These digital pulse generators can be triggered by software, hardware trigger or can trigger

each other allowing to form complex pulse schemes to drive external equipment or experiments. The digital pulse generators can be output on the existing multi-XIO lines (X0, X1, ...) or can be used to trigger other pulse generators internally. Time resolution of the pulse generator depends on the cards type and the selected sampling rate and can be found in the technical data section.

The pulse generator option is a firmware option and can be later installed on all shipped cards.

Firmware Option Multi-Tone DDS

DDS - Direct Digital Synthesis - is a method for generating arbitrary periodic waveforms from a single, fixed-frequency reference clock and is widely used in signal generation applications. The DDS functionality implemented on Spectrum

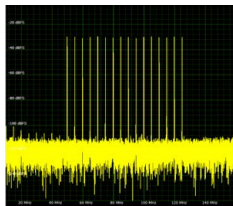

Instrumentation's AWGs is based on the principle of adding multiple

"DDS cores" to generate a multi-carrier (multi-tone) signal, with each carrier having its own well-defined frequency, amplitude and phase. The right-hand frequency plot shows 16 tones. In addition to these static parameters, there are also built in dynamic parameters like frequency and amplitude slope to allow for intrinsic linear changes for multiple cores.

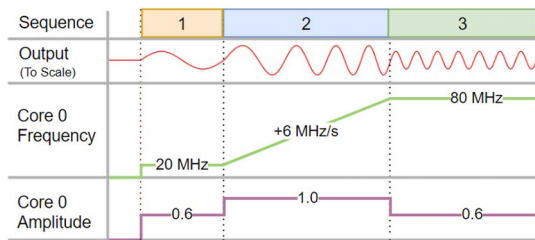

Above, the example sequence of three commands for a single core, shows a fixed 20 MHz frequency with 60% amplitude in step 1, a 10 seconds frequency ramp with 6 MHz/s slope and full 100% am-

plitude in step 2 and finally, in step 3, a fixed 80 MHz frequency with 50% amplitude. Each step consists of only 3 to 4 single line commands to set the mode, frequency, amplitude and timing.

Each of the cores can either be added together and output, or specific groups of cores can be added together and output on a specific hardware output channel. A fast DMA mode allows the use of individual DDS command sequences for programming more advanced frequency changes, like shaped slopes or modulated sine signals.

The DDS option is a firmware option that can be field installed on all shipped cards and generatorNETBOX products. Each single internal AWG card of the generatorNETBOX can get this option with the full set of DDS cores for each AWG card.

Technical Data



Only figures that are given with a maximum reading or with a tolerance reading are guaranteed specifications. All other figures are typical characteristics that are given for information purposes only. Figures are valid for products stored for at least 2 hours inside the specified operating temperature range, after a 30 minute warm-up, after running an on-board calibration and with proper cooled products. All figures have been measured in lab environment with an environmental temperature between 20°C and 25°C and an altitude of less than 100 m.

Analog Outputs

Resolution		16 bit																					
D/A Interpolation		no interpolation																					
		<table border="1"> <thead> <tr> <th>M4i.662x/M4x.662x DN2.662/DN6.662x DN2.82x-04</th> <th>M4i.663x/M4x.663x DN2.663/DN6.663 DN2.82x-02</th> <th>high bandwidth version (1.25 GS/s + option -hbw)</th> </tr> </thead> <tbody> <tr> <td>±80 mV up to ±2.5 V</td> <td>±80 mV up to ±2 V</td> <td>±80 mV up to ±480 mV</td> </tr> <tr> <td>±160 mV up to ±5 V</td> <td>±160 mV up to ±4 V</td> <td>±160 mV up to ±960 mV</td> </tr> <tr> <td>1 mV</td> <td>1 mV</td> <td>1 mV</td> </tr> <tr> <td>2 mV</td> <td>2 mV</td> <td>2 mV</td> </tr> <tr> <td>1.5 ns</td> <td>1.1 ns</td> <td>440 ps</td> </tr> <tr> <td>1.5 ns</td> <td>1.1 ns</td> <td>n.a.</td> </tr> </tbody> </table>	M4i.662x/M4x.662x DN2.662/DN6.662x DN2.82x-04	M4i.663x/M4x.663x DN2.663/DN6.663 DN2.82x-02	high bandwidth version (1.25 GS/s + option -hbw)	±80 mV up to ±2.5 V	±80 mV up to ±2 V	±80 mV up to ±480 mV	±160 mV up to ±5 V	±160 mV up to ±4 V	±160 mV up to ±960 mV	1 mV	1 mV	1 mV	2 mV	2 mV	2 mV	1.5 ns	1.1 ns	440 ps	1.5 ns	1.1 ns	n.a.
M4i.662x/M4x.662x DN2.662/DN6.662x DN2.82x-04	M4i.663x/M4x.663x DN2.663/DN6.663 DN2.82x-02	high bandwidth version (1.25 GS/s + option -hbw)																					
±80 mV up to ±2.5 V	±80 mV up to ±2 V	±80 mV up to ±480 mV																					
±160 mV up to ±5 V	±160 mV up to ±4 V	±160 mV up to ±960 mV																					
1 mV	1 mV	1 mV																					
2 mV	2 mV	2 mV																					
1.5 ns	1.1 ns	440 ps																					
1.5 ns	1.1 ns	n.a.																					
Output amplitude into 50 Ω termination	software programmable																						
Output amplitude into high impedance loads	software programmable																						
Stepsize of output amplitude (50 Ω termination)																							
Stepsize of output amplitude (high impedance)																							
10% to 90% rise/fall time of 0 V to 480 mV pulse																							
10% to 90% rise/fall time of 0 V to 2000 mV pulse																							
Output offset	fixed	0 V																					
Output Amplifier Path Selection	automatically by driver	Low Power path: ±80 mV to ±480 mV (into 50 Ω) High Power path: ±420 mV to ±2.5 V/±2 V (into 50 Ω)																					
Output Amplifier Setting Hysteresis	automatically by driver	420 mV to 480 mV (if output is using low power path it will switch to high power path at 480 mV. If output is using high power path it will switch to low power path at 420 mV)																					
Output amplifier path switching time		10 ms (output disabled while switching)																					
Filters	software programmable	bypass with no filter or one fixed filter																					
DAC Differential non linearity (DNL)	DAC only	±0.5 LSB typical																					
DAC Integral non linearity (INL)	DAC only	±1.0 LSB typical																					
Output resistance		50 Ω																					
Output coupling		DC																					
Minimum output load		0 Ω (short circuit safe)																					
Output accuracy	Low power path High power path	±0.5 mV ±0.1% of programmed output amplitude ±1.0 mV ±0.2% of programmed output amplitude																					
Offset temperature drift	after warm-up and calibration	TBD																					
Gain temperature drift	after warm-up and calibration	TBD																					
Calibration	External	External calibration calibrates the on-board references. All calibration constants are stored in non-volatile memory. A yearly external calibration is recommended.																					

Trigger

Available trigger modes	software programmable	External, Software, Window, Re-Arm, Or/And, Delay, PXI (M4x only)	
Trigger edge	software programmable	Rising edge, falling edge or both edges	
Trigger delay	software programmable	0 to (8GSamples - 32) = 8589934560 Samples in steps of 32 samples	
Multi, Gate: re-arming time		40 samples	
Trigger to Output Delay	sample rate ≤ 625 MS/s sample rate > 625 MS/s	238.5 sample clocks + 16 ns (valid for all modes except SPCSEQ_ENDLOOPONTRIG) 476.5 sample clocks + 16 ns (valid for all modes except SPCSEQ_ENDLOOPONTRIG)	
Memory depth	software programmable	32 up to [installed memory / number of active channels] samples in steps of 32	
Multiple Replay segment size	software programmable	16 up to [installed memory / 2 / active channels] samples in steps of 16	
Trigger accuracy (all sources)		1 sample	
Minimum external trigger pulse width		≥ 2 samples	
External trigger		Ext0	Ext1
External trigger impedance	software programmable	50 Ω / 1 kΩ	1 kΩ
External trigger coupling	software programmable	AC or DC	fixed DC
External trigger type		Window comparator	Single level comparator
External input level		±10 V (1 kΩ), ±2.5 V (50 Ω),	±10 V
External trigger sensitivity (minimum required signal swing)		2.5% of full scale range	2.5% of full scale range = 0.5 V
External trigger level	software programmable	±10 V in steps of 10 mV	±10 V in steps of 10 mV
External trigger maximum voltage		±30V	±30 V
External trigger bandwidth DC	50 Ω 1 kΩ	DC to 200 MHz DC to 150 MHz	n.a. DC to 200 MHz
External trigger bandwidth AC	50 Ω	20 kHz to 200 MHz	n.a.
Minimum external trigger pulse width		≥ 2 samples	≥ 2 samples

Clock

Clock Modes	software programmable	internal PLL, external reference clock, Star-Hub sync (generatorNETBOX and M4i only), PXI Reference Clock (M4x only)
Internal clock accuracy		≤ ±20 ppm
Internal clock setup granularity		8 Hz (internal reference clock only, restrictions apply to external reference clock)
Settable Clock speeds		50 MHz to max sampling clock
Clock Setting Gaps		750 to 757 MHz, 1125 to 1145 MHz (no sampling clock possible in these gaps)
External reference clock range	software programmable	≥ 10 MHz and ≤ 1.25 GHz
External reference clock input impedance		50 Ω fixed
External reference clock input coupling		AC coupling
External reference clock input edge		Rising edge
External reference clock input type		Single-ended, sine wave or square wave
External reference clock input swing	square wave	0.3 V peak-peak up to 3.0 V peak-peak
External reference clock input swing	sine wave	1.0 V peak-peak up to 3.0 V peak-peak
External reference clock input max DC voltage		±30 V (with max 3.0 V difference between low and high level)
External reference clock input duty cycle requirement		45% to 55%
External reference clock output type		Single-ended, 3.3V LVPECL
Clock output	sampling clock ≤71.68 MHz	Clock output = sampling clock/4
Clock output	sampling clock >71.68 MHz	Clock output = sampling clock/8
Star-Hub synchronization clock modes	software selectable	Internal clock, external reference clock

Sequence Replay Mode (Mode available starting with firmware V1.14)

Number of sequence steps	software programmable	1 up to 4096 (sequence steps can be overloaded at runtime)
Number of memory segments	software programmable	2 up to 64k (segment data can be overloaded at runtime)
Minimum segment size	software programmable	384 samples (1 active channel), 192 samples (2 active channels), 96 samples (4 active channels), in steps of 32 samples.
Maximum segment size	software programmable	2 GS / active channels / number of sequence segments (round up to the next power of two)
Loop Count	software programmable	1 to (1M - 1) loops
Sequence Step Commands	software programmable	Loop for #Loops, Next, Loop until Trigger, End Sequence
Special Commands	software programmable	Data Overload at runtime, sequence steps overload at runtime, readout current replayed sequence step
Limitations for synchronized products		Software commands changing the sequence as well as „Loop until trigger“ are not synchronized between cards. This also applies to multiple AWG modules in a generatorNETBOX.

Multi Purpose I/O lines (front-plate)

Number of multi purpose lines		three, named X0, X1, X2
Input: available signal types	software programmable	Asynchronous Digital-In
Input: impedance		10 kΩ to 3.3 V
Input: maximum voltage level		-0.5 V to +4.0 V
Input: signal levels		3.3 V LVTTTL
Output: available signal types	software programmable	Asynchronous Digital-Out, Synchronous Digital-Out, Trigger Output, Run, Arm, Marker Output, System Clock
Output: impedance		50 Ω
Output: signal levels		3.3 V LVTTTL
Output: type		3.3V LVTTTL, TTL compatible for high impedance loads
Output: drive strength		Capable of driving 50 Ω loads, maximum drive strength ±48 mA
Output: update rate		sampling clock

Option M4i.xxxx-DDS (multi-tone DDS firmware)

Number of available DDS cores per AWG card		23
DDS core routing options	software programmable	Routed cores can individually be activated for output Ch0: 8, 12, 16 or 20 cores; Ch1: 1 or 5 cores Ch2: 1 or 5 cores Ch3: 1 or 5 cores
DDS commands	individual for each core	Set Frequency,, Set Amplitude, Set Phase, Frequency Slope, Amplitude Slope
DDS commands	for all cores	Reset, Execute Now, Execute at Trigger/Timer
DDS command transfer mode		single or DMA
DDS time resolution		1.25 GS/s (800 ps)
DDS timer resolution	software programmable	83.2 ns up to 27.48 s with a resolution of 6.4 ns
DDS frequency range	per core programmable	0 Hz up to 1.25 GHz with a resolution of 0.29 Hz. Frequencies above 625 MHz (Nyquist-Shannon) are mirrored
DDS amplitude range	per core programmable	-1.0 up to +1.0 with a resolution of 1/[2 ³²] programmed in relation to output level: +1.0 = 100% output, -1.0 = 100% inverted output
DDS phase range	per core programmable	-360° to +360° with a resolution of 360/4096 = 0.088°
DDS command buffer	single mode DMA mode	4k commands 512M commands in on-board RAM. More commands can reside in DMA buffer in PC-RAM.
Min user software to analog output latency	single mode DMA mode	10 us 20 us
Max continuous DDS command rate	single mode DMA mode	400 kHz 10 MHz
External trigger to DDS output change		ca. 554 ns (692 samples at 800 ps per sample)
Number of DDS options per generatorNETBOX		Each generatorNETBOX DN2.66x and DN6.66x contains multiple AWGs with either two or four channels. The user can individually decide how many of these internal AWGs should be equipped with the DDS option. Each single internal AWG needs a separate license.

Option M4i.xxxx-PulseGen

Number of internal pulse generators	4
Number of pulse generator output lines	3 (Existing multi-purpose outputs X0 to X2)
Time resolution of pulse generator	Pulse generator's sampling rate is derived from instrument's sampling rate and value can be read out. Maximum possible pulse generator update rate is 22xx: 156.25 MS/s (6.4 ns) 23xx: 156.25 MS/s (6.4 ns) 44xx: 125.00 MS/s (8.0 ns) 66xx: 156.25 MS/s (6.4 ns)
Programmable output modes	Single-shot, multiple repetitions on trigger, gated
Programmable trigger sources	Software, Card Trigger, Other Pulse Generator, XIO lines.
Programmable trigger gate	None, ARM state, RUN state
Programmable length (frequency)	2 to 4G samples in steps of 1 (32 bit)
Programmable width (duty cycle)	1 to 4G samples in steps of 1 (32 bit)
Programmable delay	0 to 4G samples in steps of 1 (32 bit)
Programmable loops	0 to 4G samples in steps of 1 (32 bit) - 0 = infinite
Output level of digital pulse generators	Please see section of multi-purpose I/O lines

Connectors

Analog Channels		SMA female (one for each single-ended input)	Cable-Type: Cab-3mA-xx-xx
Clock Input		SMA female	Cable-Type: Cab-3mA-xx-xx
Clock Output		SMA female	Cable-Type: Cab-3mA-xx-xx
Trg0 Input		SMA female	Cable-Type: Cab-3mA-xx-xx
Trg1 Input		SMA female	Cable-Type: Cab-3mA-xx-xx
X0/Trigger Output/Timestamp Reference Clock	programmable direction	SMA female	Cable-Type: Cab-3mA-xx-xx
X1	programmable direction	SMA female	Cable-Type: Cab-3mA-xx-xx
X2	programmable direction	SMA female	Cable-Type: Cab-3mA-xx-xx

Connection Cycles

All connectors have an expected lifetime as specified below. Please avoid to exceed the specified connection cycles or use connector savers

SMA connector	500 connection cycles
Power connector	500 connection cycles
LAN connector	500 connection cycles

Option digitizerNETBOX/generatorNETBOX embedded server (DN2.xxx-Emb, DN6.xxx-Emb)

CPU	Intel Quad Core 2 GHz	
System memory	4 GByte RAM	
System data storage	Internal 128 GByte SSD	
Development access	Remote Linux command shell (ssh), no graphical interface (GUI) available	
Accessible Hardware	Full access to Spectrum instruments, LAN, front panel LEDs, RAM, SSD	
Integrated operating system	OpenSuse 12.2 with kernel 4.4.7.	
Internal PCIe connection	DN2.20, DN2.46, DN2.47, DN2.49, DN2.59, DN2.60, DN2.65 DN6.46, DN6.49, DN6.59, DN6.65, DN2.80, DN2.81 DN2.22, DN2.44, DN2.66 DN6.22, DN6.44, DN6.66, DN2.82	PCIe x1, Gen1 PCIe x1, Gen2

Ethernet specific details

LAN Connection	Standard RJ45
LAN Speed	Auto Sensing: GBit Ethernet, 100BASE-T, 10BASE-T
LAN IP address	DHCP (IPv4) with AutoIP fall-back (169.254.x.y), fixed IP (IPv4)
Sustained Streaming speed	programmable DN2.20, DN2.46, DN2.47, DN2.49, DN2.60 up to 70 MByte/s DN6.46, DN6.49 DN2.59, DN2.65, DN2.22, DN2.44, DN2.66 up to 100 MByte/s DN6.59, DN6.65, DN6.22, DN6.44, DN6.66
Used TCP/UDP Ports	Webserver: 80 mDNS Daemon: 5353 VISA Discovery Protocol: 111, 9757 UPNP Daemon: 1900 Spectrum Remote Server: 1026, 5025

AC Power connection details (default configuration)

Mains AC power supply	Input voltage: 100 to 240 VAC, 50 to 60 Hz
AC power supply connector	IEC 60320-1-C14 (PC standard coupler)
Power supply cord	power cord included for Schuko contact (CEE 7/7)

DC 24 V Power supply details (option DN2.xxxx-DC24)

Input Voltage	18 V to 36 V
Power supply connector	screw terminal
Power supply cord	no cord included

Serial connection details (DN2.xxx with hardware ≥ V11)

Serial connection (RS232)	For diagnostic purposes only. Do not use, unless being instructed by a Spectrum support agent.
---------------------------	--

Certification, Compliance, Warranty

Conformity Declaration	EN 17050-1:2010	General Requirements
EU Directives	2014/30/EU 2014/35/EU 2011/65/EU 2006/1907/EC 2012/19/EU	EMC - Electromagnetic Compatibility LVD - Electrical equipment designed for use within certain voltage limits RoHS - Restriction of the use of certain hazardous substances in electrical and electronic equipment REACH - Registration, Evaluation, Authorisation and Restriction of Chemicals WEEE - Waste from Electrical and Electronic Equipment
Compliance Standards	EN 61010-1: 2010 EN 61187:1994 EN 61326-1:2021 EN 61326-2-1:2021 EN IEC 63000:2018	Safety regulations for electrical measuring, control, regulating and laboratory devices - Part 1: General requirement Electrical and electronic measuring equipment - Documentation Electrical equipment for measurement, control and laboratory use EMC requirements - Part 1: General requirements EMC requirements - Part 2-1: Particular requirements - Test configurations, operational conditions and performance criteria for sensitive test and measurement equipment for EMC unprotected applications Technical documentation for the assessment of electrical and electronic products with respect to the restriction of hazardous substances
Product warranty	5 years starting with the day of delivery	
Software and firmware updates	Life-time, free of charge	

Bandwidth and Slewrate

	Filter	Output Amplitude	M4i.663x-x8 M4x.663x-x8 DN2.663-xx DN6.663-xx DN2.82x-02	M4i.662x-x8 M4x.662x-x8 DN2.662-xx DN6.662-xx DN2.82x-04
Maximum Output Rate			1.25 GS/s	625 MS/s
-3dB Bandwidth	no Filter	±480 mV	400 MHz	200 MHz
-3dB Bandwidth	no Filter	±1000 mV	320 MHz	200 MHz
-3dB Bandwidth	no Filter	±2000 mV	320 MHz	200 MHz
-3dB Bandwidth	Filter	all	65 MHz	65 MHz
Slewrate	no Filter	±480 mV	4.5 V/ns	2.25 V/ns

Dynamic Parameters

	M4i.662x-x8 M4x.662x-x8 DN2.662-xx DN6.662-xx DN2.82x-04							
Test - Samplerate	625 MS/s			625 MS/s		625 MS/s		
Output Frequency	10 MHz			50 MHz		50 MHz		
Output Level in 50 Ω	±480 mV	±1000mV	±2500mV	±480 mV	±2500mV	±480 mV	±2500mV	
Used Filter	none			none		Filter enabled		
NSD (typ)	-150 dBm/Hz	-149 dBm/Hz	-149 dBm/Hz	-150 dBm/Hz	-149 dBm/Hz	-150 dBm/Hz	-149 dBm/Hz	
SNR (typ)	70.7 dB	72.4 dB	63.1 dB	65.3 dB	64.4 dB	67.5 dB	69.4 dB	
THD (typ)	-73.3 dB	-70.5 dB	-49.7 dB	-64.1 dB	-39.1 dB	-68.4 dB	-50.4 dB	
SINAD (typ)	69.0 dB	67.7 dB	49.5 dB	61.6 dB	39.1 dB	64.9 dB	50.3 dB	
SFDR (typ), excl harm.	98 dB	98 dB	99 dB	86 dB	76 dB	88 dB	89 dB	
ENOB (SINAD)	11.2	11.0	8.0	10.0	6.2	10.5	8.1	
ENOB (SNR)	11.5	11.7	10.2	10.5	10.4	10.9	11.2	

	M4i.663x-x8 M4x.663x-x8 DN2.663-xx DN6.663-xx DN2.82x-02							
Test - Samplerate	1.25 GS/s			1.25 GS/s		1.25 GS/s		
Output Frequency	10 MHz			50 MHz		50 MHz		
Output Level in 50 Ω	±480 mV	±1000mV	±2000mV	±480 mV	±2000mV	±480 mV	±2000mV	
Used Filter	none			none		Filter enabled		
NSD (typ)	-150 dBm/Hz	-149 dBm/Hz	-149 dBm/Hz	-150 dBm/Hz	-149 dBm/Hz	-150 dBm/Hz	-149 dBm/Hz	
SNR (typ)	70.5 dB	72.1 dB	71.4 dB	65.2 dB	65.0 dB	67.2 dB	68.2 dB	
THD (typ)	-74.5 dB	-73.5 dB	-59.1 dB	-60.9 dB	-43.9 dB	-67.9 dB	-63.1 dB	
SINAD (typ)	69.3 dB	69.7 dB	59 dB	59.5 dB	43.9 dB	64.5 dB	61.9 dB	
SFDR (typ), excl harm.	96 dB	97 dB	98 dB	85 dB	84 dB	87 dB	87 dB	
ENOB (SINAD)	11.2	11.2	9.5	9.6	6.9	10.4	10.0	
ENOB (SNR)	11.5	11.5	11.5	10.5	10.5	10.9	11.0	

THD and SFDR are measured at the given output level and 50 Ohm termination with a high resolution M3i.4860/M4i.4450-x8 data acquisition card and are calculated from the spectrum. Noise Spectral Density is measured with built-in calculation from an HP E4401B Spectrum Analyzer. All available D/A channels are activated for the tests. SNR and SFDR figures may differ depending on the quality of the used PC. NSD = Noise Spectral Density, THD = Total Harmonic Distortion, SFDR = Spurious Free Dynamic Range.

SFDR and THD versus signal frequency

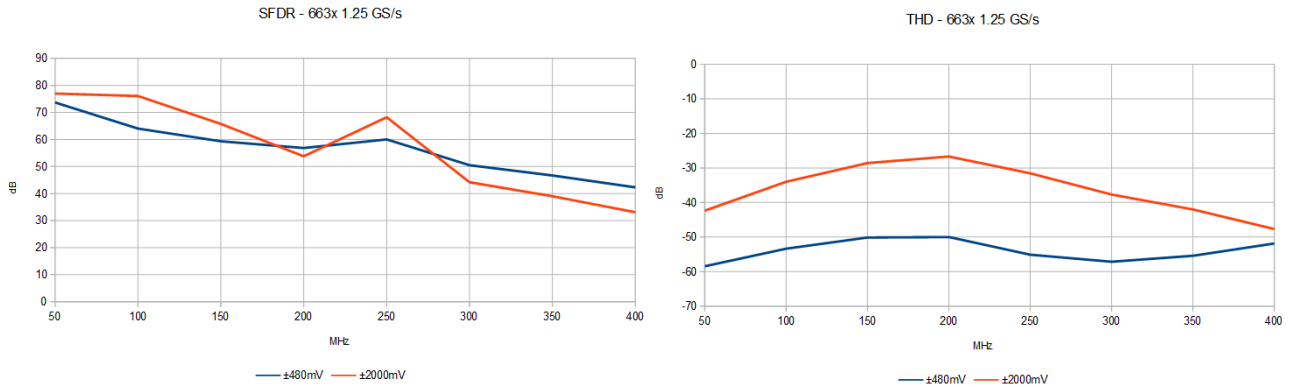

- Measurements done with a spectrum analyzer bandwidth of 1.5 GHz
- Please note that the bandwidth of the high range output is limited to 320 MHz
- Please note that the output bandwidth limit also affects the THD as harmonics higher than the bandwidth are filtered

DN2 specific Technical Data

Environmental and Physical Details DN2.xxx

Dimension of Chassis without connectors or bumpers	L x W x H	366 mm x 267 mm x 87 mm
Dimension of Chassis with 19" rack mount option	L x W x H	366 mm x 482.6 mm x 87 mm (2U height)
Weight (1 internal acquisition/generation module)		6.3 kg, with rack mount kit: 6.8 kg
Weight (2 internal acquisition/generation modules)		6.7 kg, with rack mount kit 7.2 kg
Warm up time		20 minutes
Operating temperature		0°C to 40°C
Storage temperature		-10°C to 70°C
Humidity		10% to 90%
Dimension of packing (single DN2)	L x W x H	470 mm x 390 mm x 180 mm
Volume weight of Packing (single DN2)		7.0 kg

Power Consumption

	230 VAC		12 VDC		24 VDC	
DN2.662-02, DN2.663-02	0.22 A	50 W	TBD	TBD	TBD	TBD
DN2.662-04	0.24 A	55 W	TBD	TBD	TBD	TBD
DN2.662-08, DN2.663-04	0.42 A	95 W	TBD	TBD	TBD	TBD

MTBF

MTBF	100000 hours
------	--------------

Block diagram of generatorNETBOX DN2

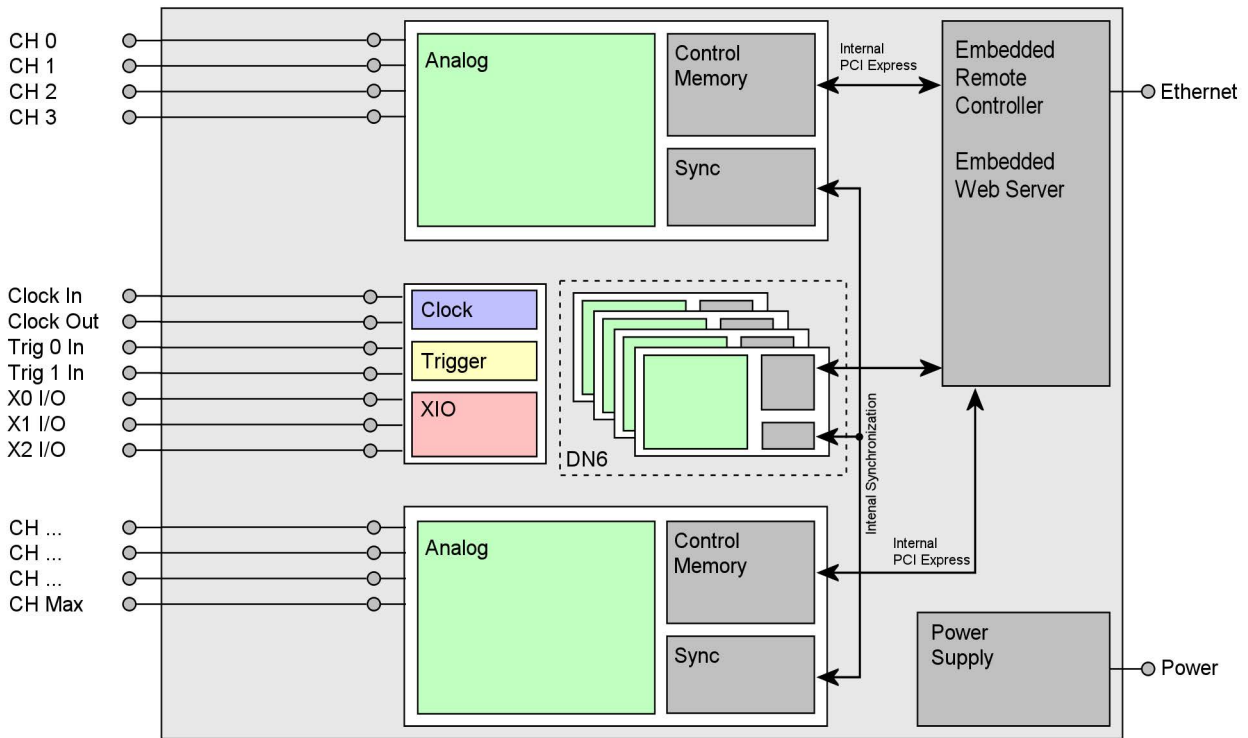

Block diagram of generatorNETBOX module DN2.66x

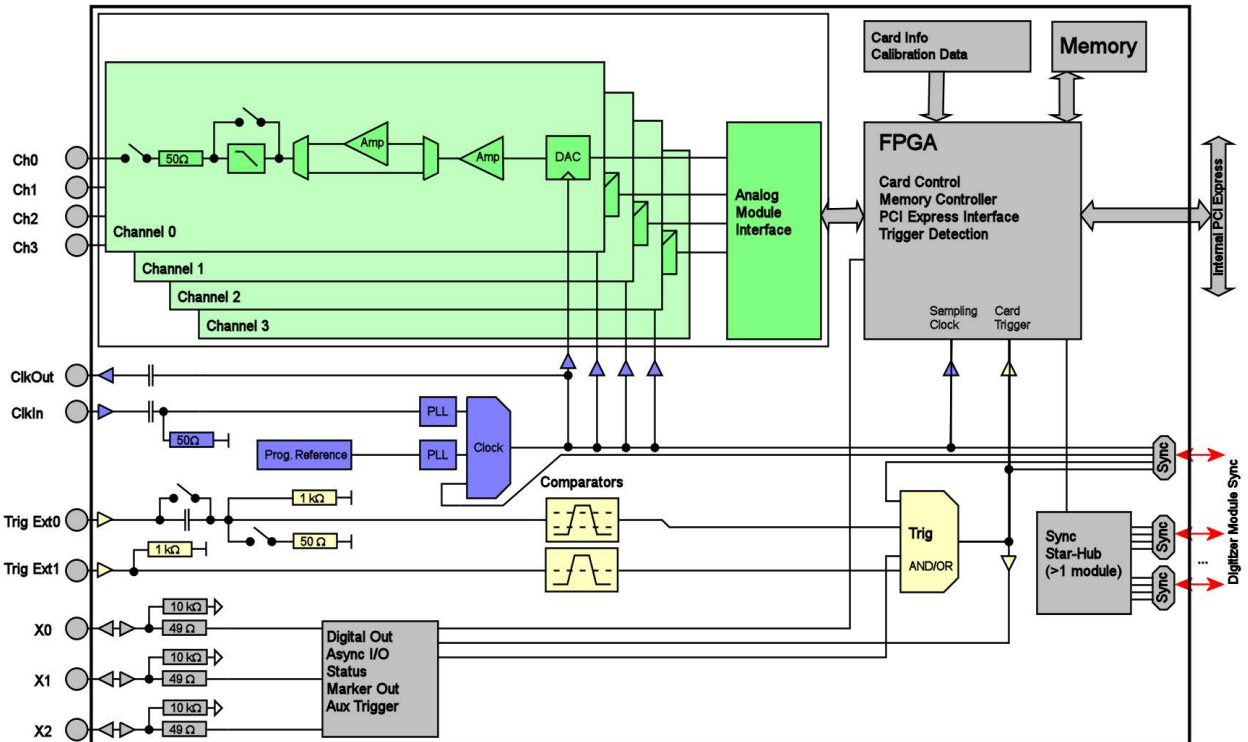

Order Information

The generatorNETBOX is equipped with a large internal memory and supports standard replay, FIFO replay (streaming), Multiple Replay, Gated Replay, Continuous Replay (Loop), Single-Restart as well as Sequence. Operating system drivers for Windows/Linux 32 bit and 64 bit, drivers and examples for C/C++, IVI (Function Generator class), LabVIEW (Windows), MATLAB (Windows and Linux), .NET, Delphi, Java, Python, Julia and a Professional license of the oscilloscope software SBench 6 are included.

The system is delivered with a connection cable meeting your countries power connection. Additional power connections with other standards are available as option.

generatorNETBOX DN2 - Ethernet/LXI Interface

Order no.	D/A Resolution	Bandwidth	Single-Ended Channels	Update Rate	Installed Memory
DN2.662-02	16 Bit	200 MHz	2 channels	625 MS/s	1 x 2 GS
DN2.662-04	16 Bit	200 MHz	4 channels	625 MS/s	1 x 2 GS
DN2.662-08	16 Bit	200 MHz	8 channels	625 MS/s	2 x 2 GS
DN2.663-02	16 Bit	400 MHz	2 channels	1.25 GS/s	1 x 2 GS
DN2.663-04	16 Bit	400 MHz	4 channels	1.25 GS/s	2 x 2 GS

Options

Order no.	Option
DN2.xxx-Rack	19" rack mounting set for self mounting
DN2.xxx-Emb	Extension to Embedded Server: CPU, more memory, SSD. Access via remote Linux secure shell (ssh)
DN2.xxx-DC12	12 VDC internal power supply. Replaces AC power supply. Accepts 9 V to 18 V DC input. Screw terminals.
DN2.xxx-DC24	24 VDC internal power supply. Replaces AC power supply. Accepts 18 V to 36 V DC input. Screw terminals
DN2.xxx-BTPWR	Boot on Power On: the digitizerNETBOX/generatorNETBOX/hybridNETBOX automatically boots if power is switched on.
DN2.66x-mrk6	Add 3 additional XIO lines (marker output) of second internal AWG to front-plate. (only available for DN2.662-08 and DN2.663-04)
M4i.663x-hbw	High bandwidth option 600 MHz. Available for 663 products with 1.25 GS/s only. Output level limited to ± 480 mV into 50 Ω . Needs external reconstruction filter. One option needed per internal AWG card.

Firmware Options

Order no.	Option
M4i.66xx-DDS	Firmware Option multi-carrier DDS mode: adds 23 programmable DDS cores to a single internal AWG. Please refer to the model overview in the data sheet to see how many AWG are installed in each dedicated DN2. Each core can be programmed with single commands for frequency, amplitude, phase, frequency slope, amplitude slope.
M4i.xxxx-PulseGen	Firmware Option: adds 4 freely programmable digital pulse generators that use the XIO lines for output (later installation by firmware - upgrade available)

Calibration

Order no.	Option
DN2.xxx-Recal	Recalibration of complete digitizerNETBOX/generatorNETBOX/hybridNETBOX DN2 including calibration protocol

Standard SMA Cables

The standard adapter cables are based on RG174 cables and have a nominal attenuation of 0.3 dB/m at 100 MHz and 0.5 dB/m at 250 MHz. For high speed signals we recommend the low loss cables series CHF.

for Connections	Connection	Length	to BNC male	to BNC female	to SMB female	to MMCX male	to SMA male
All	SMA male	80 cm	Cab-3mA-9m-80	Cab-3mA-9f-80	Cab-3f3mA-80	Cab-1m-3mA-80	Cab-3mA-3mA-80
All	SMA male	200 cm	Cab-3mA-9m-200	Cab-3mA-9f-200	Cab-3f3mA-200	Cab-1m-3mA-200	Cab-3mA-3mA-200
Probes (short)	SMA male	5 cm		Cab-3mA-9f-5			

Low Loss SMA Cables

The low loss adapter cables are based on MF141 cables and have an attenuation of 0.3 dB/m at 500 MHz and 0.5 dB/m at 1.5 GHz. They are recommended for signal frequencies of 200 MHz and above.

Order no.	Option
CHF-3mA-3mA-200	Low loss cables SMA male to SMA male 200 cm
CHF-3mA-9m-200	Low loss cables SMA male to BNC male 200 cm

Technical changes and printing errors possible

SBench, digitizerNETBOX, generatorNETBOX and hybridNETBOX are registered trademarks of Spectrum Instrumentation GmbH. Microsoft, Visual C++, Windows, Windows 98, Windows NT, Window 2000, Windows XP, Windows Vista, Windows 7, Windows 8, Windows 10 and Windows 11 are trademarks/registered trademarks of Microsoft Corporation. LabVIEW, DASyLab, Diadem and LabWindows/CVI are trademarks/registered trademarks of National Instruments Corporation. MATLAB is a trademark/registered trademark of The Mathworks, Inc. Delphi and C++ Builder are trademarks/registered trademarks of Embarcadero Technologies, Inc. IVI is a registered trademark of the IVI Foundation. Oracle and Java are registered trademarks of Oracle and/or its affiliates. Python is a trademark/registered trademark of Python Software Foundation. Julia is a trademark/registered trademark of Julia Computing, Inc. PCIe, PCI Express and PCI-X and PCI-SIG are trademarks of PCI-SIG. LXI is a registered trademark of the LXI Consortium. PICMG and CompactPCI are trademarks of the PCI Industrial Computer Manufacturers Group. Intel and Intel Core i3, Core i5, Core i7, Core i9 and Xeon are trademarks and/or registered trademarks of Intel Corporation. AMD, Opteron, Sempron, Phenom, FX, Ryzen and EPYC are trademarks and/or registered trademarks of Advanced Micro Devices. Arm is a trademark or registered trademark of Arm Limited (or its subsidiaries). NVIDIA, CUDA, GeForce, Quadro, Tesla and Jetson are trademarks/registered trademarks of NVIDIA Corporation.